

Display trays and RSC cases in a single palletizing solution

Up to 12.5 cases per minute in
various collations of cases and trays



Requirements summarized

- Case dimensions:
340 - 625 mm x 112 - 350 mm x 167 - 514 mm /
13.3 - 24.6" x 4.4 - 13.9" x 6.6 - 20.3"
- Carton contents: Consumer product
- Maximum 12.5 case per minute

Challenges summarized

- Display trays and RSC cases
- Adequate operator access in limited space
- Integrated stretch wrapper

MACHINE LAYOUT

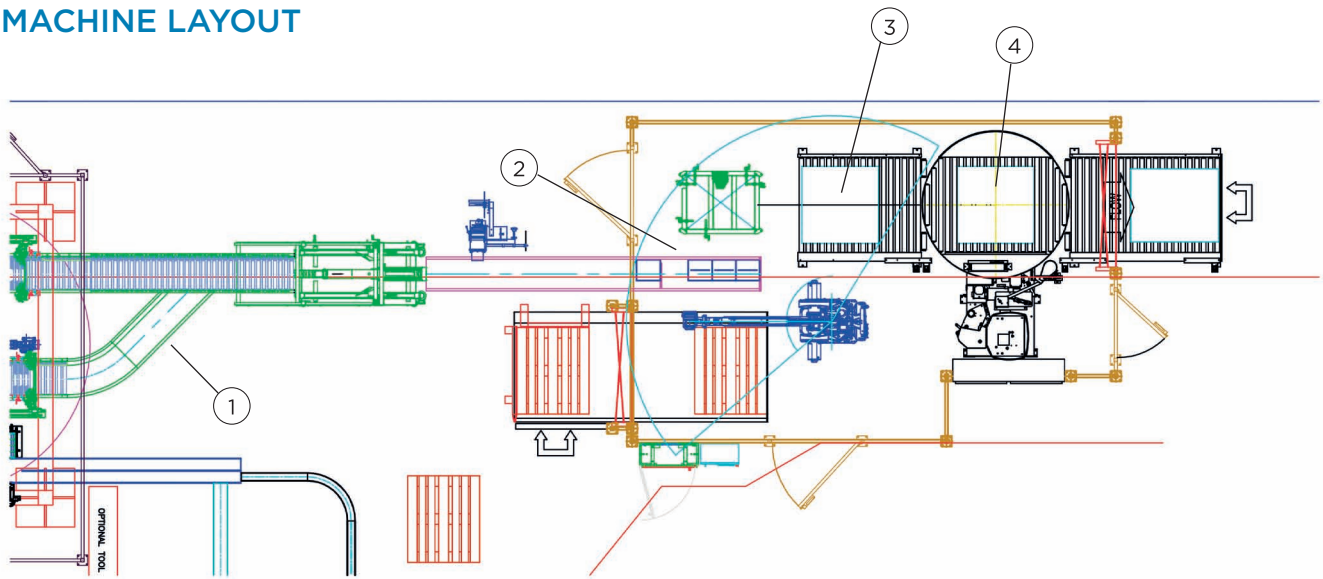

Solution highlights

- Very flexible case and tray palletizing system
- Automatic product collation at the infeed
- Flexible for a wide range of case/tray sizes
- Automatic stretch wrapping within the robotic work cell
- Discharge of completed pallets

1. Conveyor system transport cases or trays to the robotic palletizer
2. Infeed system for collating products
3. Robotic palletizing of cases and/or trays
4. Automatic stretch wrapping of pallets within the robotic palletizing system

All information given in this document is dependent upon final machine specification, infeed arrangement, product type and carton specification.

AMERICAS

EUROPE, MIDDLE EAST & AFRICA
ASIA & AUSTRALIA

Canada

The Netherlands

Singapore

Thailand

Ph: +1 905 670 7200

Ph: +31 24 648 66 55

Ph: +65 62 89 37 88

Ph: +66 23 02 14 15

sales-americas@langengroup.com

sales-europe@langengroup.com

sales-asia@langengroup.com

sales-asia@langengroup.com

